

Heller

FERGUSON PETIT GRIS TE-20 + FF-30 + DIORAMA

50326



Français

La Standard Motor Company de Coventry (Grande-Bretagne) a fabriqué des tracteurs Ferguson à partir de 1946 (TE = Tractor England). En France, ils ont été assemblés par Standard Hotchkiss à Saint Denis (modèles TE-20, surnommé Petit-Gris) à partir de 1952. 1956 a été converti en une construction entièrement française (modèles FF30) jusqu'à l'arrêt de la production en 1958. Le TE-20 est équipé d'un «attelage trois points», qui a été inventé par Harry Ferguson et se retrouve dans tous les tracteurs modernes aujourd'hui. Toujours de couleur grise, il est devenu un grand succès commercial disponible en 3 largeurs: standard, étroit et vigneron. Le FF-30 était un TE-20 avec des différences mineures (forme du siège, emplacement de la batterie, moteur et châssis peints en rouge).

English

The Standard Motor Company in Coventry (Great Britain) manufactured Ferguson tractors from 1946 (TE = Tractor England). In France they were assembled by Standard Hotchkiss in Saint Denis (models TE-20, "Little Grey Fergie") from 1952. 1956 was converted to a completely French construction (models FF30) until production was discontinued in 1958. The TE-20 is equipped with a „three-point hitch“, which was invented by Harry Ferguson and can be found in every modern tractor today. Always colored gray, it became a great commercial success that was available in 3 widths: standard, narrow and winemaker. The FF-30 was a TE-20 with minor differences (seat shape, battery location, red-painted engine and chassis).

Deutsch

Die Standard Motor Company in Coventry (Großbritannien) stellte ab 1946 Ferguson-Traktoren her (TE = Traktor England). In Frankreich wurden sie ab 1952 von Standard-Hotchkiss in Saint Denis (Modelle TE-20, auch „der kleine graue“ genannt) zusammengebaut. 1956 wurde auf eine komplett französische Konstruktion umgestellt (Modelle FF30), bis die Produktion 1958 eingestellt wurde. Das Modell TE-20 ist mit einer „Dreipunktaufhängung“ ausgestattet, die von Harry Ferguson erfunden wurde und heute in jedem modernen Schlepper zu finden ist. Immer grau gefärbt, wurde er ein großer kommerzieller Erfolg, der in 3 Breiten erhältlich war: Standard, Schmal und Winzer. Der FF-30 war ein TE-20 mit kleinen Änderungen (die Form der Sitze, Lagerung der Batterie, Motor und Chassis rotgefärbt).

Español

La Standard Motor Company en Coventry (Gran Bretaña) fabricó los tractores Ferguson (TE = Tractor England) desde 1946. En Francia, Standard Hotchkiss los montó a partir de 1952 en Saint Denis (modelos TE-20, también llamado Pequeño Gris). En 1956, la compañía cambió a un diseño completamente francés (modelos FF30) hasta que la producción se interrumpió en 1958. El modelo TE-20 está equipado con un «enganche de tres puntos», inventado por Harry Ferguson, que se puede encontrar en todos los tractores modernos de hoy en día. Siempre de color gris, se convirtió en un gran éxito comercial y estaba disponible en 3 anchos: estándar, estrecho y vinícola. El FF-30 era un TE-20 con diferencias menores (forma del asiento, ubicación de la batería, motor y chasis pintados de rojo).

FERGUSON „Petit Gris“ TE-20 / FF-30

Quantité	723.310
Longueur	2,90 m
Largeur	1,62 m
Hauteur	1,32 m
Vitesse max	25 km/h
Moteur	Essence STANDARD 80 / 85
Puissance moteur	24/28 CV/PS
Masse à vide	1134 kg

FERGUSON „Petit Gris“ TE-20 / FF-30

Production	723.310
Length	2,90 m
Width	1,62 m
Height	1,32 m
Max. speed	25 km/h
Engine	Essence STANDARD 80 / 85
Power	24/28 CV/PS
Empty weight	1134 kg

FERGUSON „Petit Gris“ TE-20 / FF-30

Stückzahl	723.310
Länge	2,90 m
Breite	1,62 m
Höhe	1,32 m
Höchstgeschwindigkeit	25 km/h
Motor	Essence STANDARD 80 / 85
Leistung KW	24/28 CV/PS
Leergewicht	1134 kg

FERGUSON „Petit Gris“ TE-20 / FF-30

Numero de unidades	723.310
Comprimento	2,90 m
Largura	1,62 m
Altura	1,32 m
Velocidade máxima	25 km/h
Motor	Essence STANDARD 80 / 85
Rendimiento del motor	24/28 CV/PS
Peso sem carga	1134 kg

Nederlands

De Standard Motor Company in Coventry (Groot-Brittannië) produceerde Ferguson-tractoren vanaf 1946 (TE = Tractor England). In Frankrijk werden ze vanaf 1952 geassembleerd door Standard Hotchkiss in Saint Denis (modellen TE-20, ook wel Kleine Grey genoemd). In 1956 werden ze omgebouwd tot een volledig Franse constructie (modellen FF30), totdat de productie in 1958 werd stopgezet. De TE-20 is uitgerust met een „driepuntsbok“, uitgevonden door Harry Ferguson. Dit is tegenwoordig in elke moderne tractor te vinden. Het werd een groot commercieel succes dat steeds verkrijgbaar was in grijze kleur en in 3 breedte: standaard, smal en wijnmaker. De FF-30 was een TE-20 met kleine wijzigingen (de vorm van de zetels, de opslagruimte voor de batterijen, de motor en het roodgekleurde chassis).

FERGUSON „Petit Gris“ TE-20 / FF-30	
Hoeveelheid	723.310
Lengte	2,90 m
Breedte	1,62 m
Hoogte	1,32 m
Max. snelheid	25 km/h
Motor	Essence STANDARD 80 / 85
Motorvermogen	24/28 CV/PS
Tarra gewicht	1134 kg

Italiano

La Standard Motor Company di Coventry (Gran Bretagna) produsse trattori Ferguson dal 1946 (TE = Tractor England). In Francia venivano assemblati dalla Standard Hotchkiss a Saint Denis (modelli TE-20, detto anche Piccolo Grigio) dal 1952. Nel 1956 il modello fu convertito in una costruzione completamente francese (modelli FF30) fino a quando nel 1958 la produzione fu interrotta. Il TE-20 è dotato di una “sospensione a tre punti”, che era stata inventata da Harry Ferguson e che oggi si ritrova in ogni trattore moderno. Sempre di colore grigio, divenne un grande successo commerciale disponibile in 3 larghezze: standard, stretto e da enologo. L'FF-30 era un TE-20 con piccole differenze (forma del sedile, posizione della batteria, motore e telaio dipinti di rosso).

FERGUSON „Petit Gris“ TE-20 / FF-30	
Quantità	723.310
Lunghezza	2,90 m
Larghezza	1,62 m
Altezza	1,32 m
Velocità max.	25 km/h
Motore	Essence STANDARD 80 / 85
Potenza del motore	24/28 CV/PS
Massa a vuoto	1134 kg

1/24

FERGUSON PETIT GRIS TE-20 + FF-30

50326

PEINTURES ESSENTIELLE/ESSENTIAL PAINTS



11

Argent métallique
Silver Metallic
Silber metallisch



19

Rouge vif brillant
Bright Gloss Red
Hellrot glänzend



33

Noir mat
Black Matt
Schwarz matt



40

Gris pâle brillant
Pale Grey Gloss
Blassgrau glänzend



66

Gris brun olive mat
Olive Drab Matt
Olivegrün matt

40/19



40

TE-20



19

FF-30

2

Numéro de phase
Step number
Schrittnummer
Número de fase

56

Référence de couleur
Colour reference no
Farbangabe
Referencia de color

37

Numéro de pièce
Part number
Teilenummer
Número de pieza

6

Numéro de decal
Decal number
Abziehbildnummer
Número de calcomanía

- Si aucune teinte n'est spécifiée, peindre dans les couleurs de la version choisie. Se reporter aux pages 10 - 11 pour le détail du schéma de peinture.
- When no color is specified, paint the item with colors of chosen version. Refer to pages 10 - 11 for painting pattern.
- Wenn keine Farbe angegeben ist, Teile mit den Farben der gewählten Version bemalen. Beachten Sie die Seiten 10 - 11 für die Lackierung und Markierung.
- Cuando ningún color es especificado, pintarle con los colores del tema de la versión elegida. Vea las páginas 10 - 11 para obtener detalles de pintura.

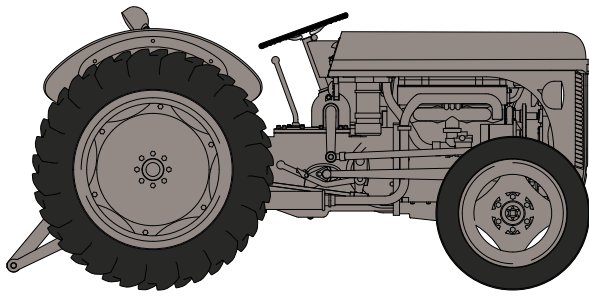

• FERGUSON TE-20

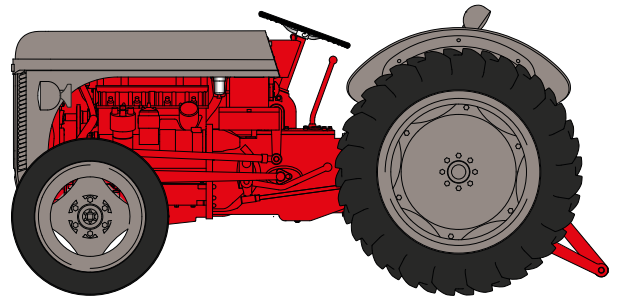

• FERGUSON FF-30

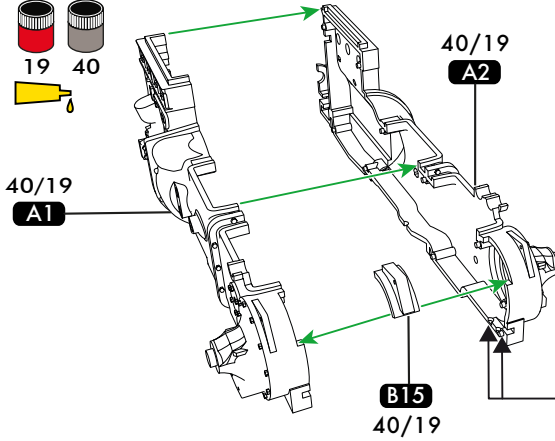
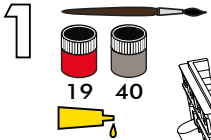

F: Percer le carter si le tracteur est doté d'un attelage.
 GB: Drill casing if tractor is equipped with a towing hook.
 D: Das Kurbelgehäuse anbohren falls der Traktor eine Anhängerkupplung hat.

ø 1.2 mm

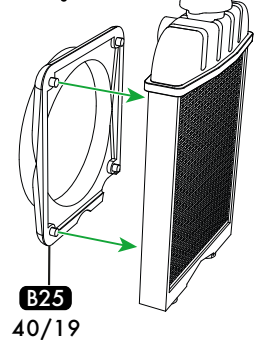
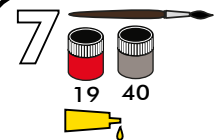
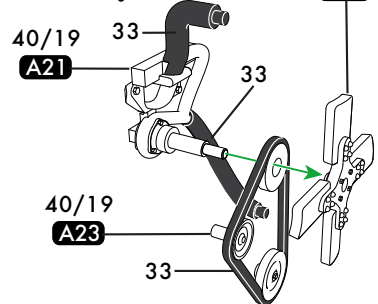
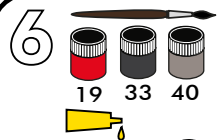
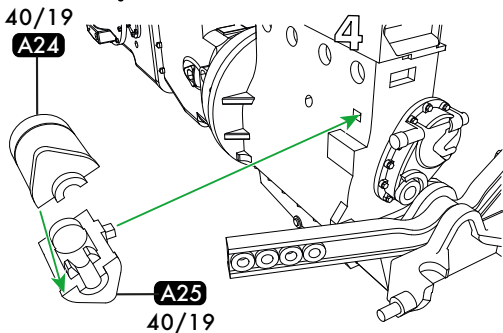
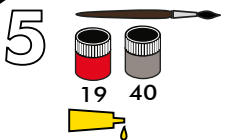
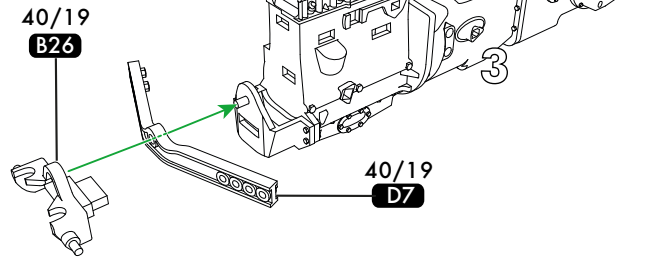
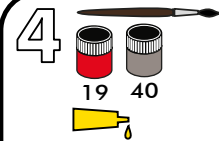
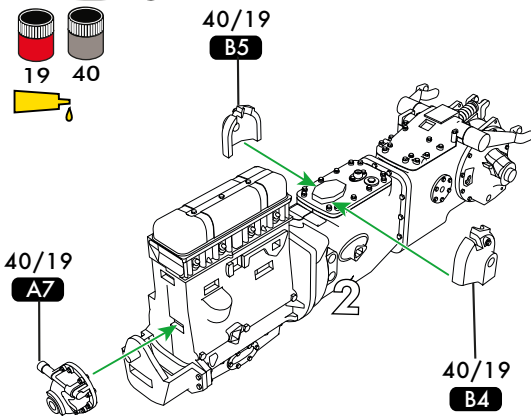
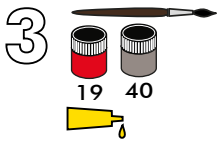
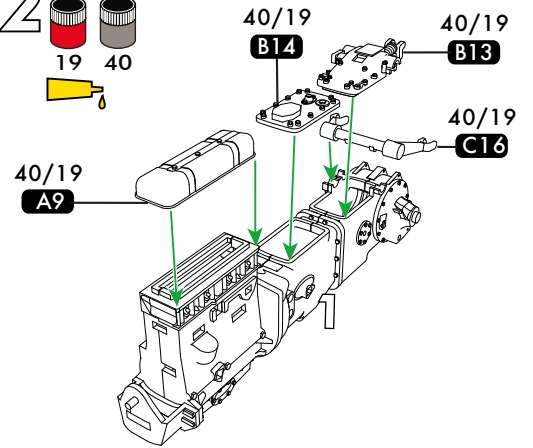
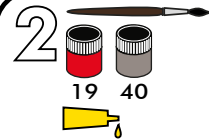

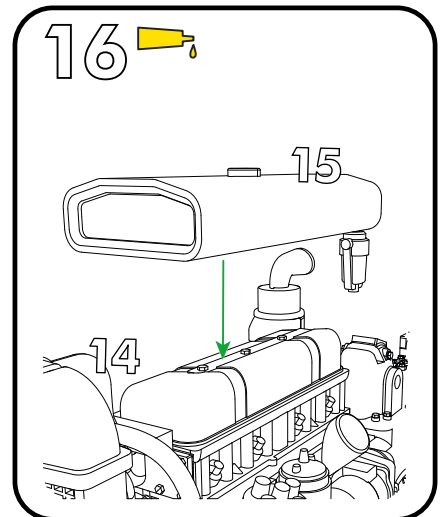
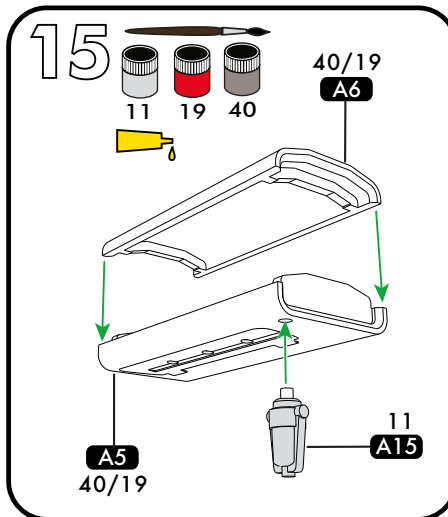
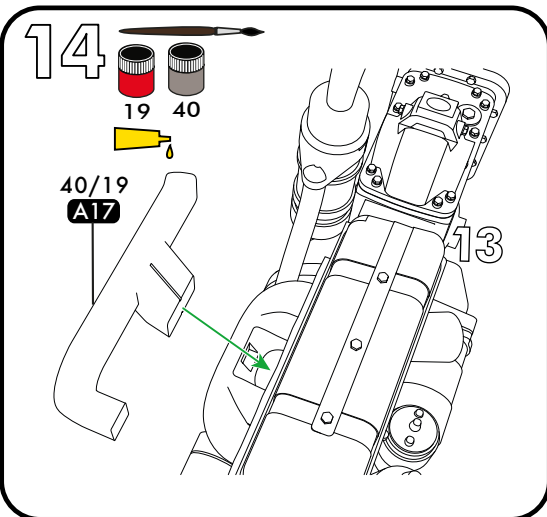
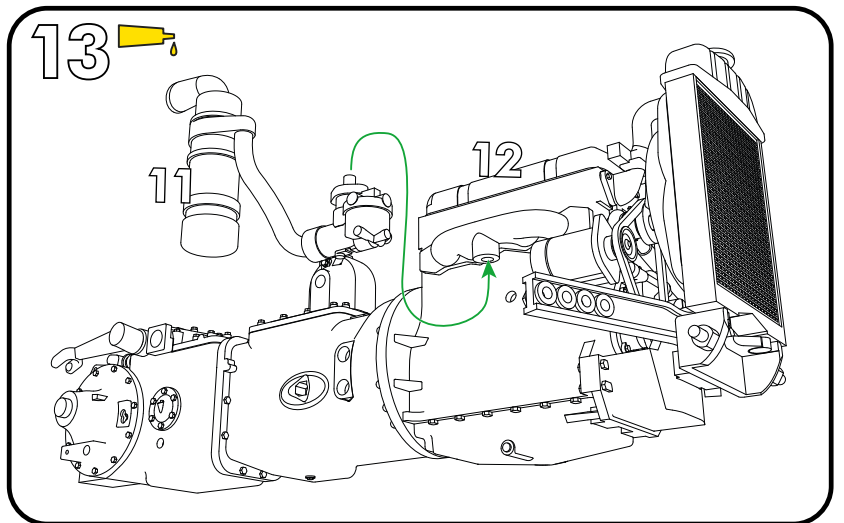
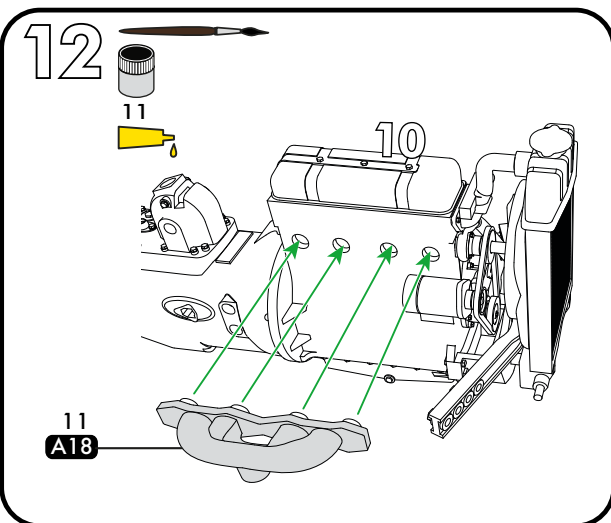
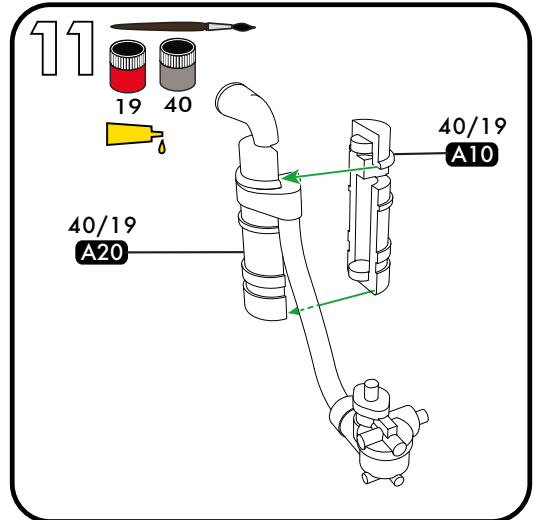
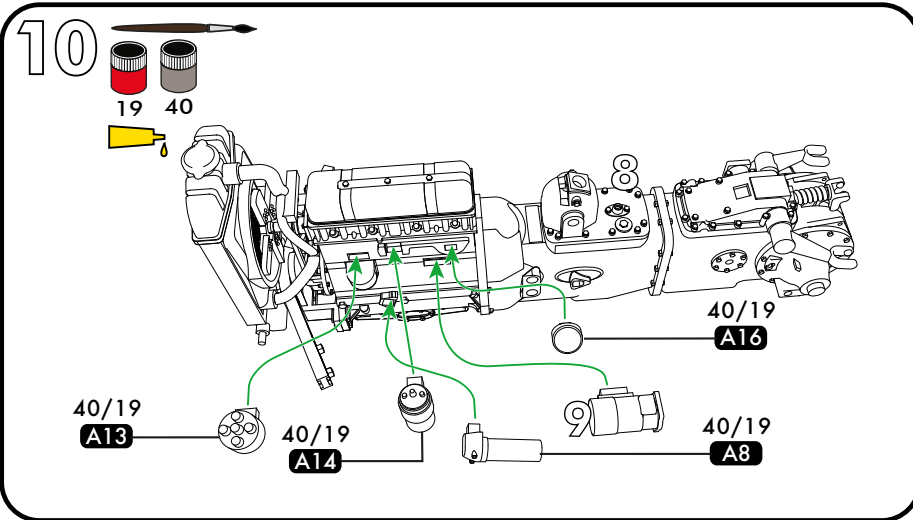
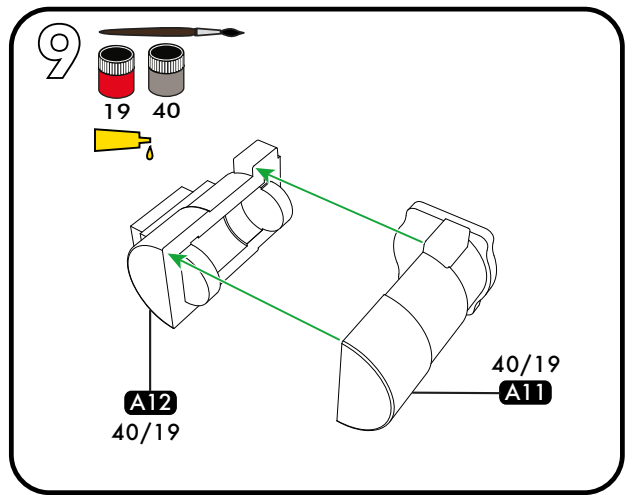
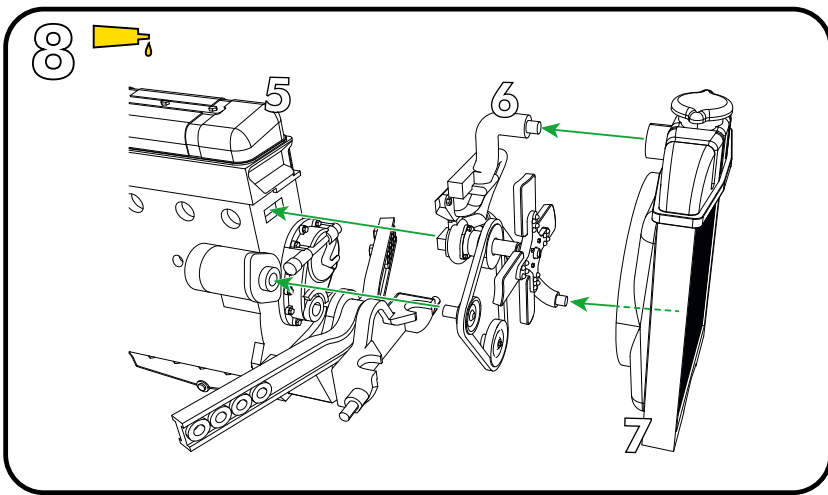

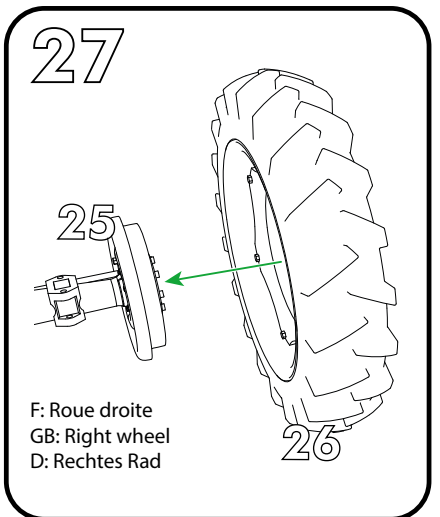
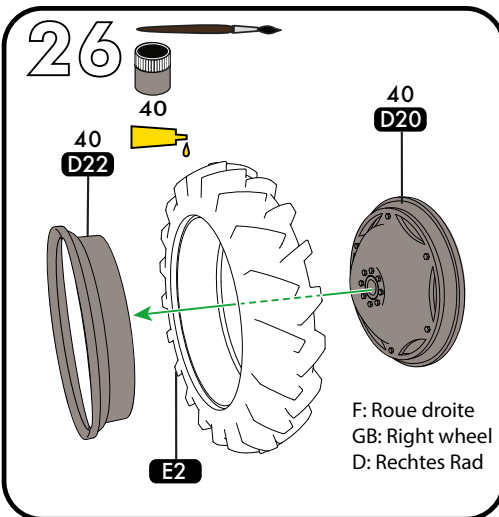
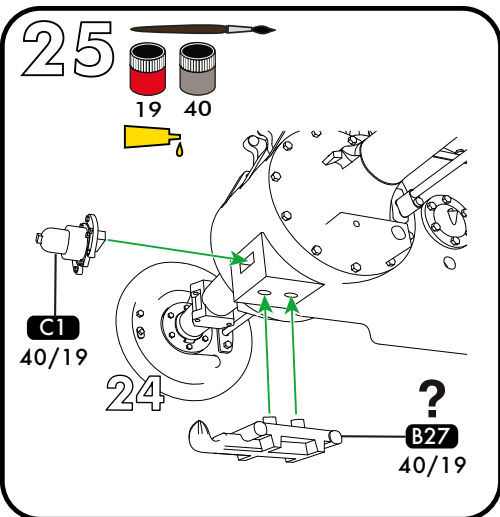
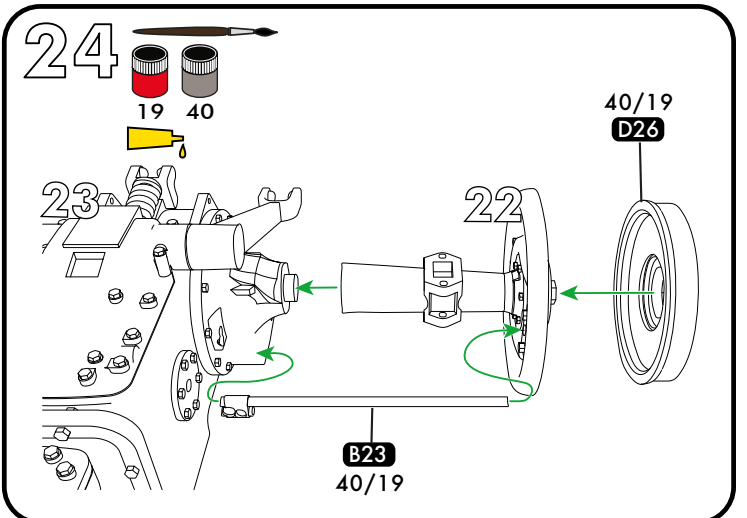
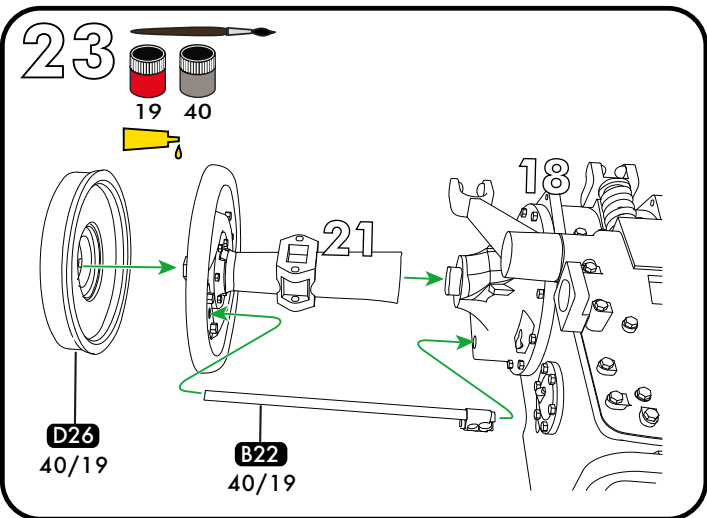
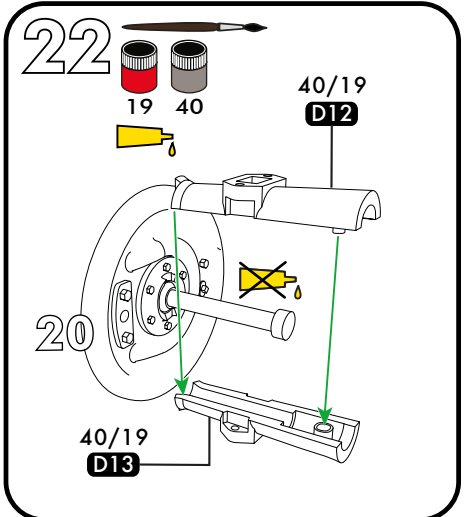
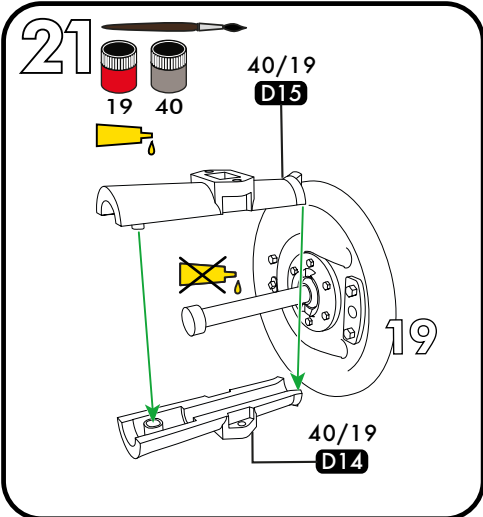
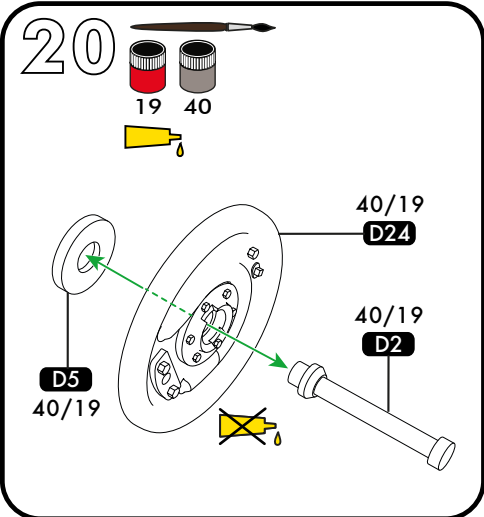
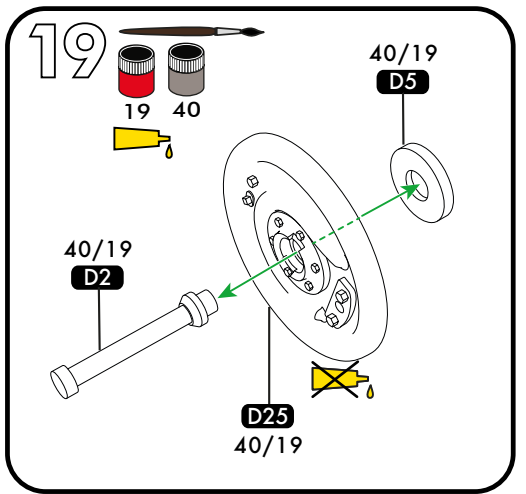
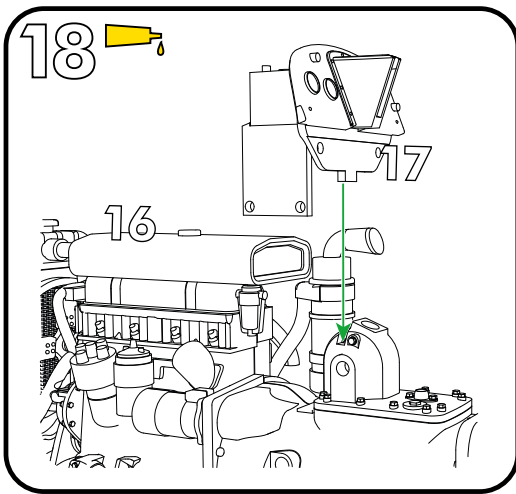
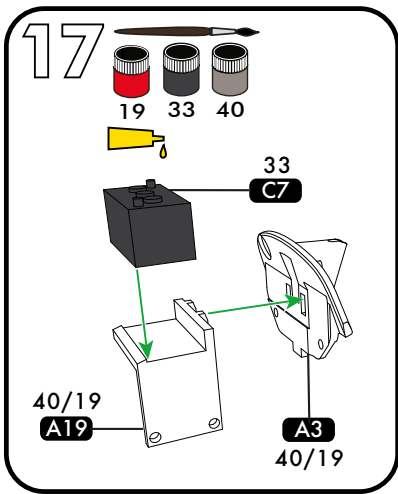

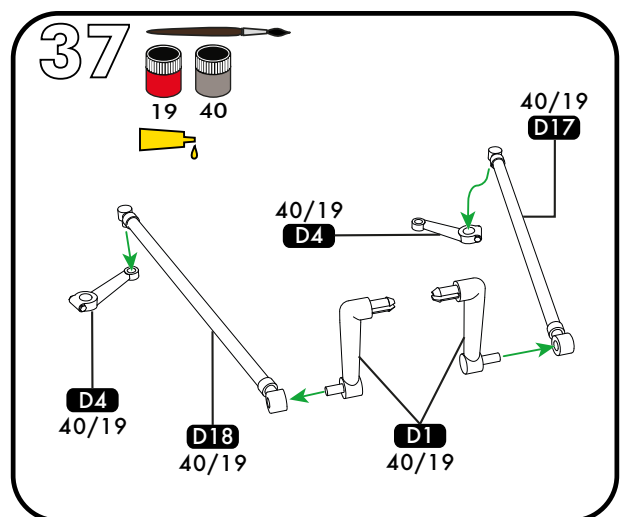
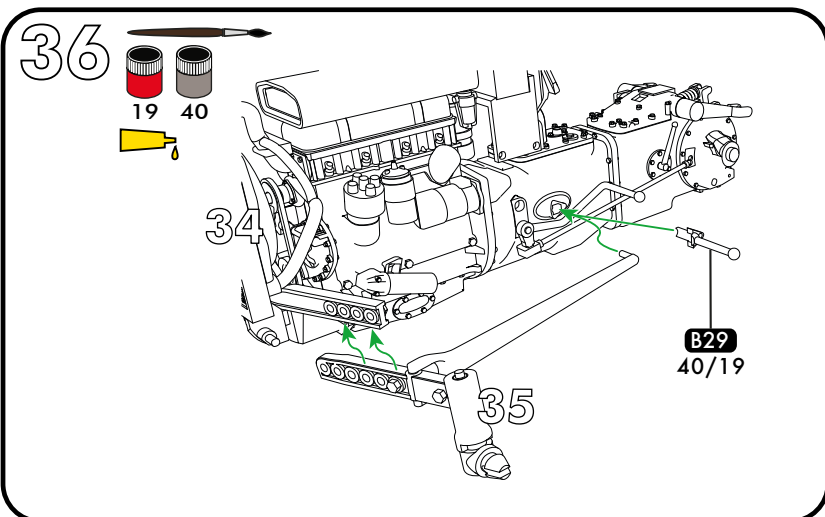
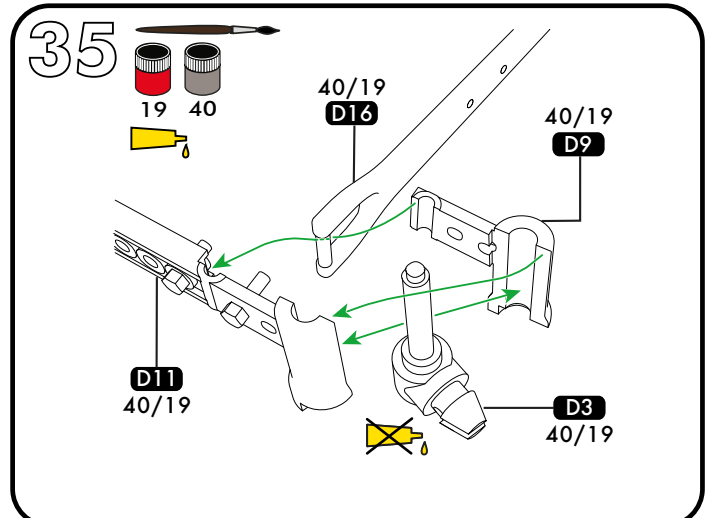
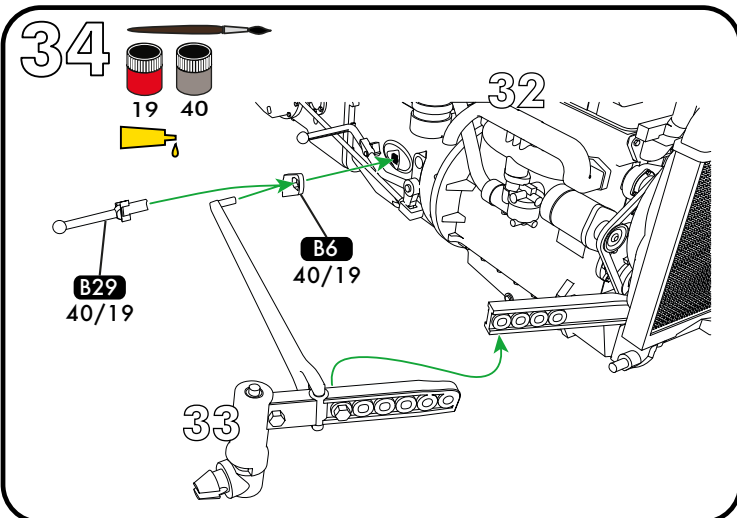
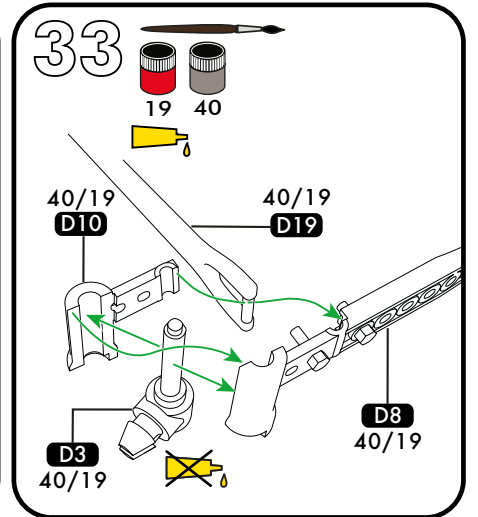
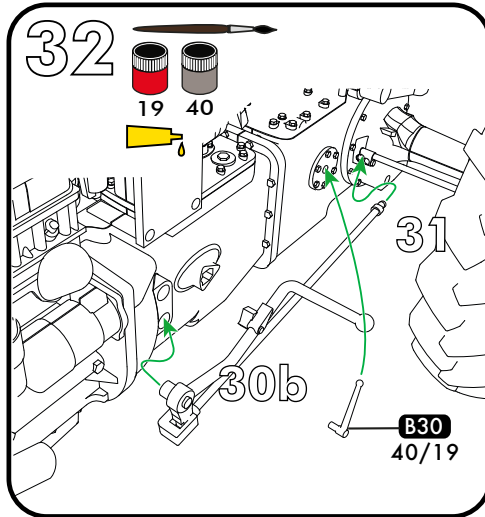
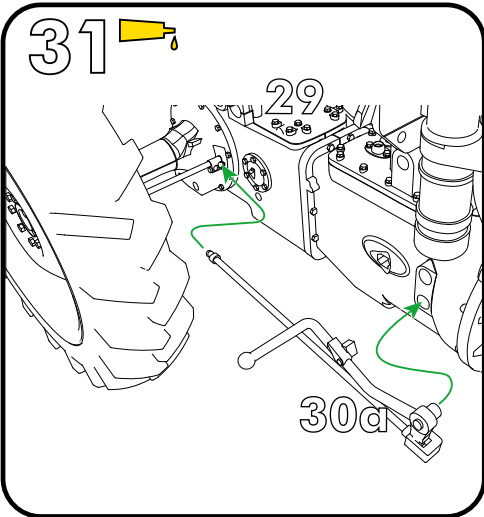
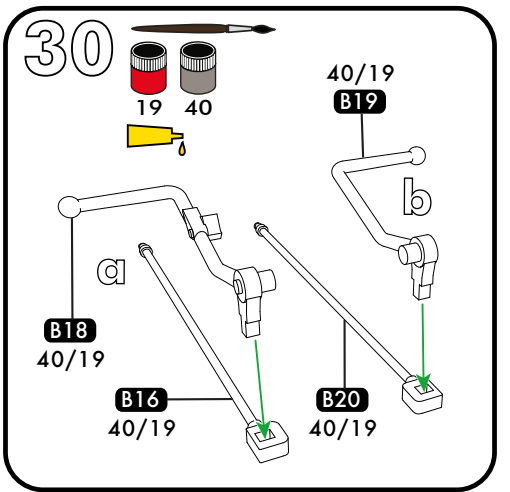
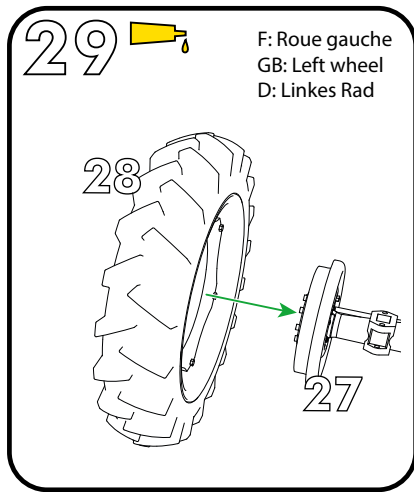
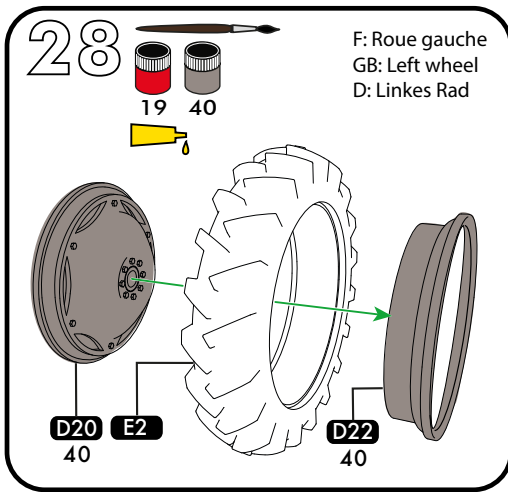

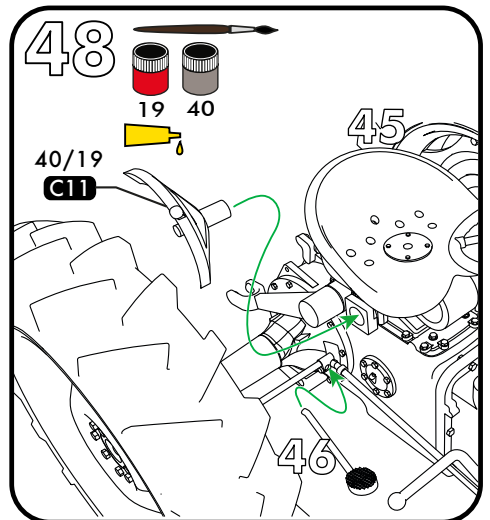
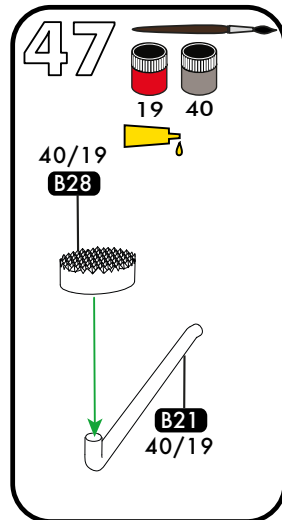
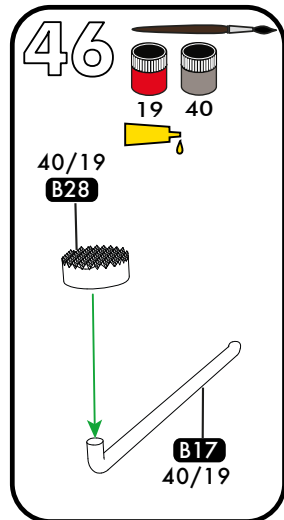
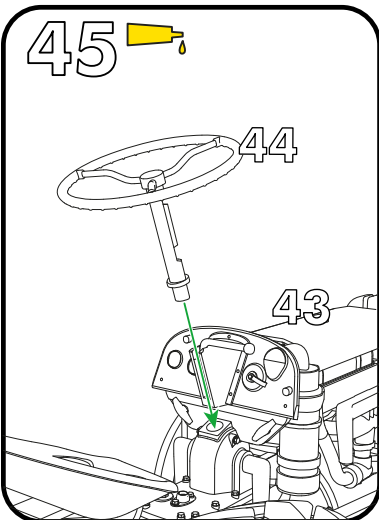
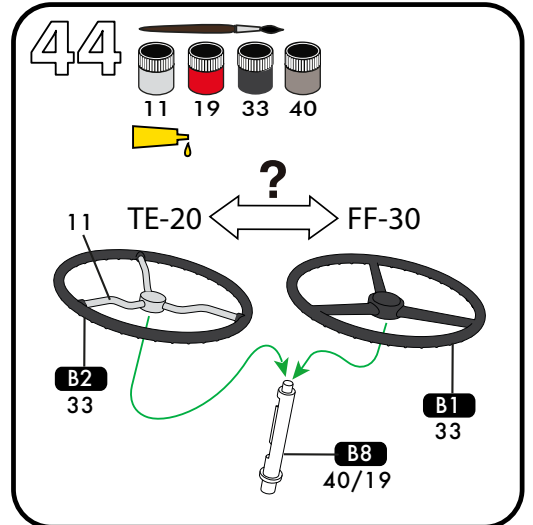
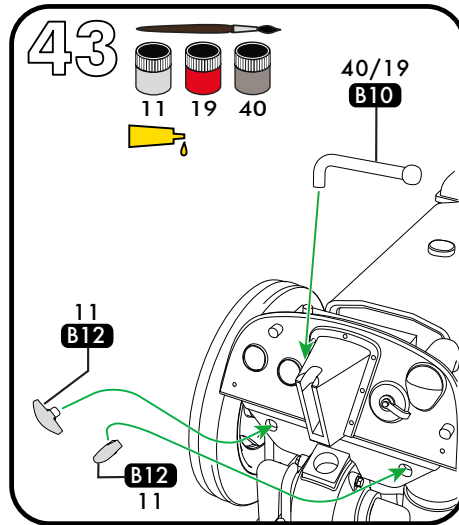
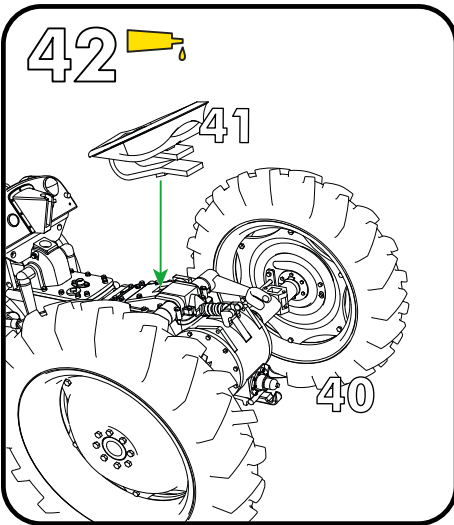
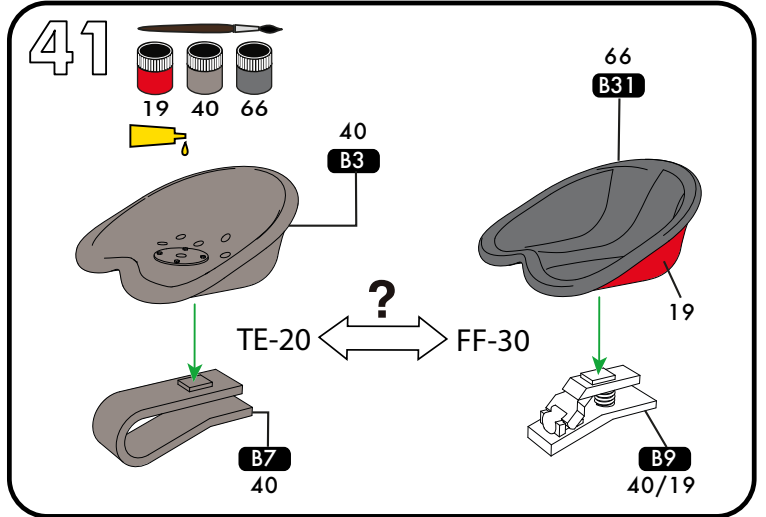
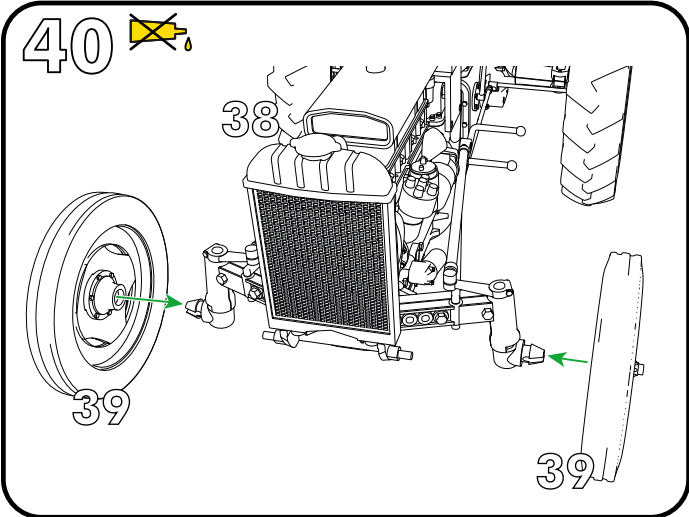
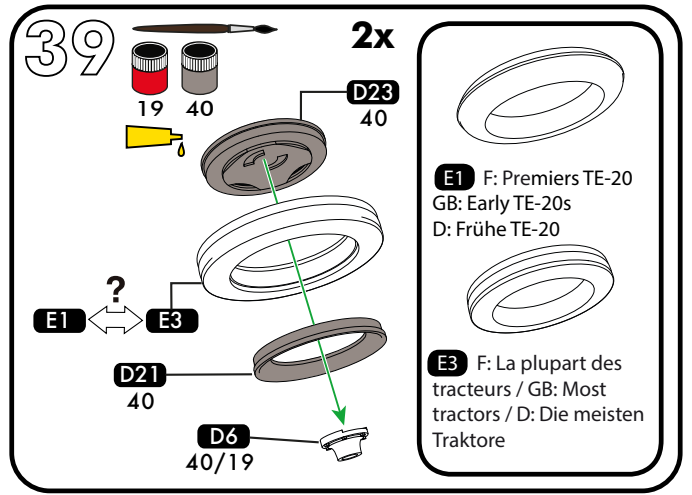
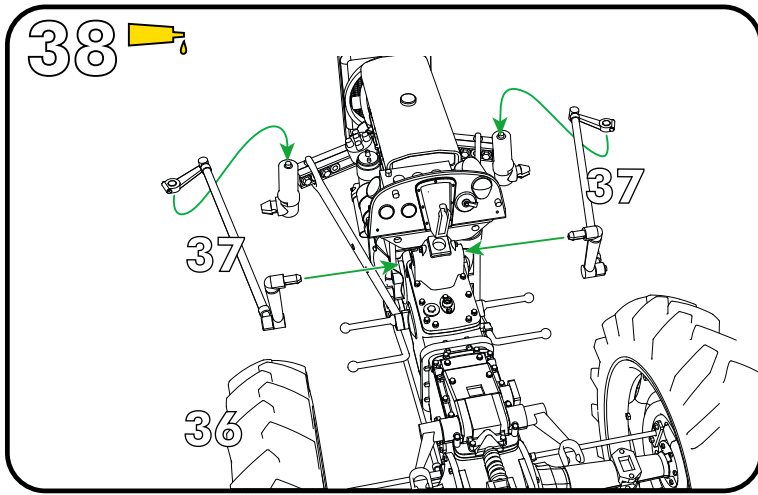

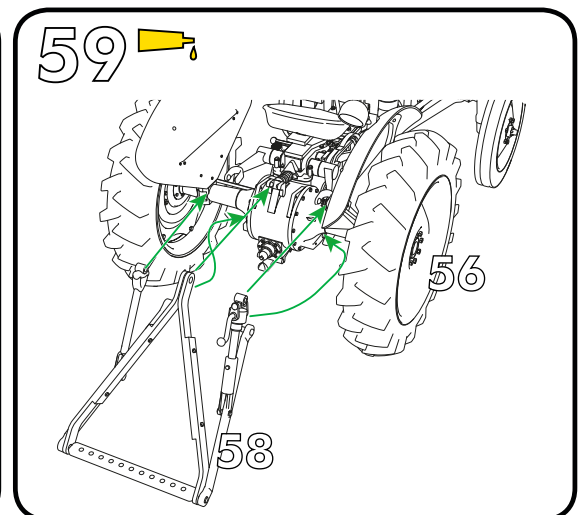
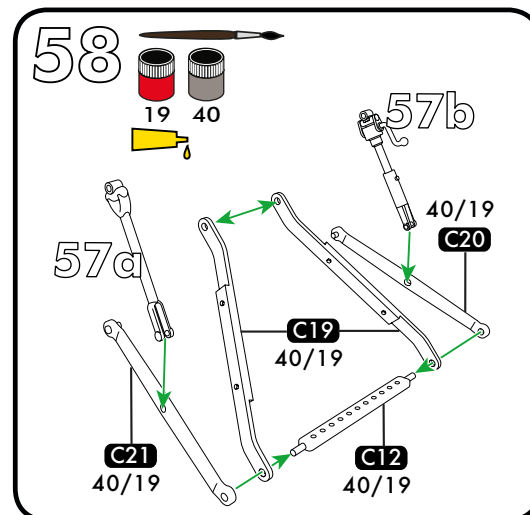
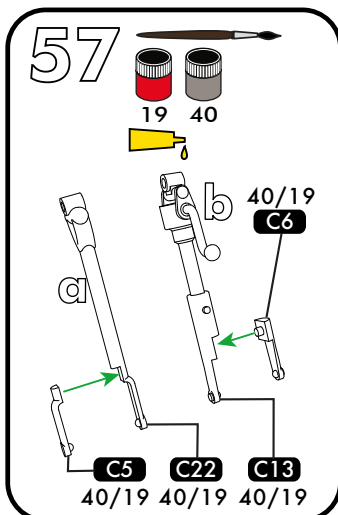
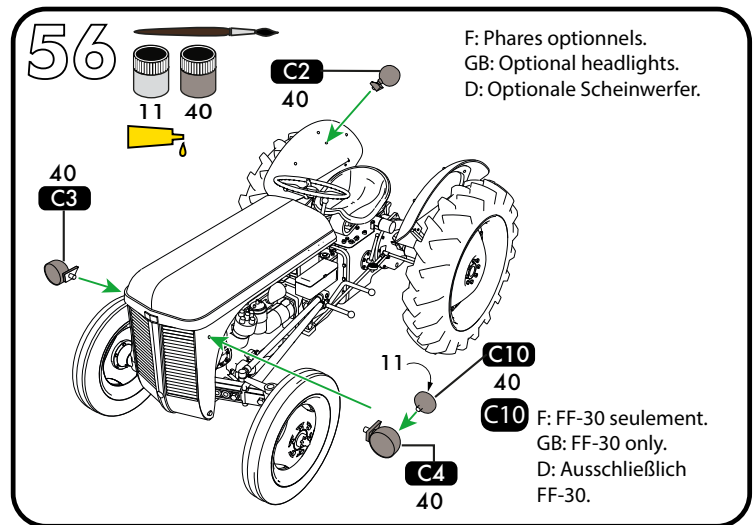
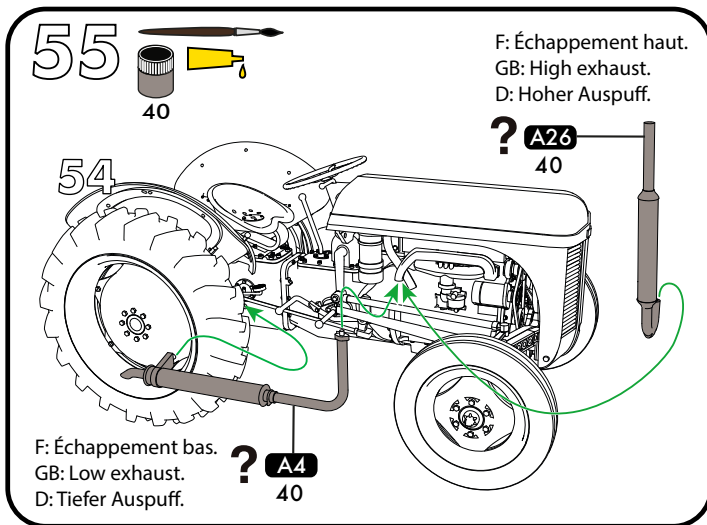
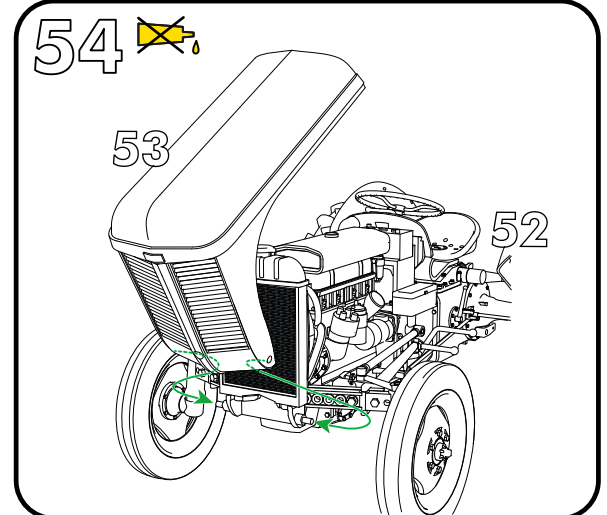
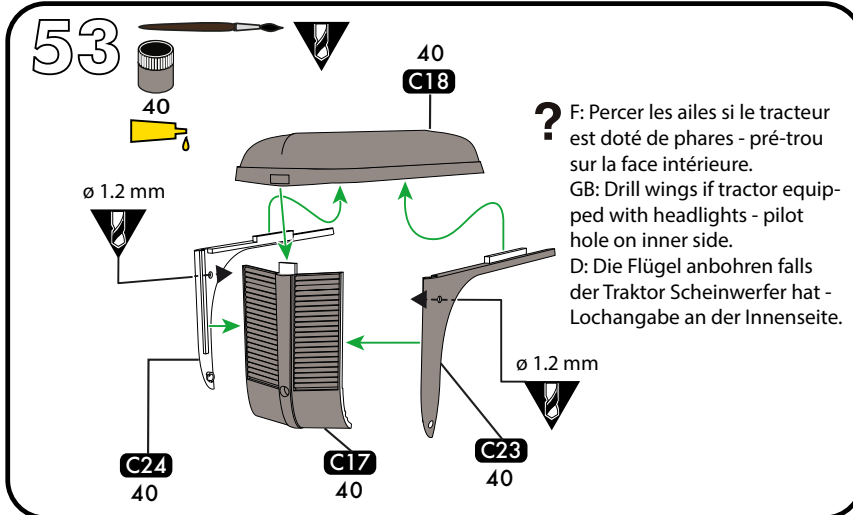
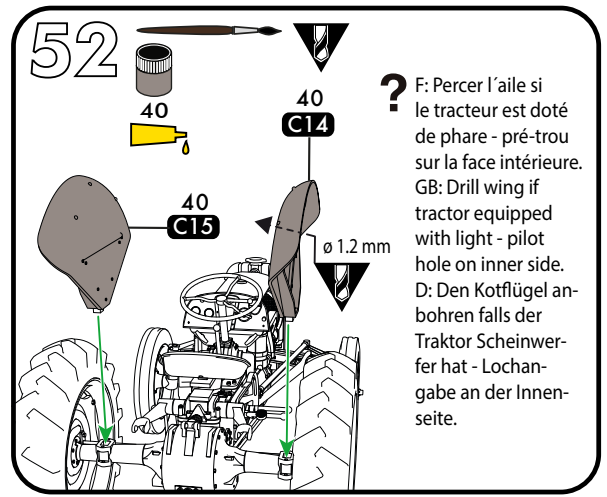
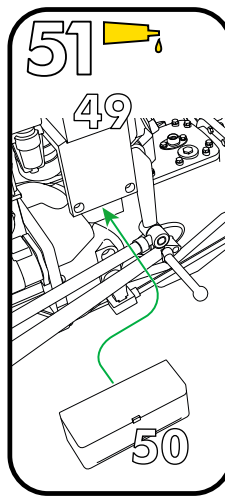
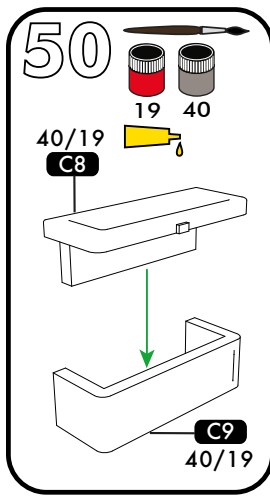
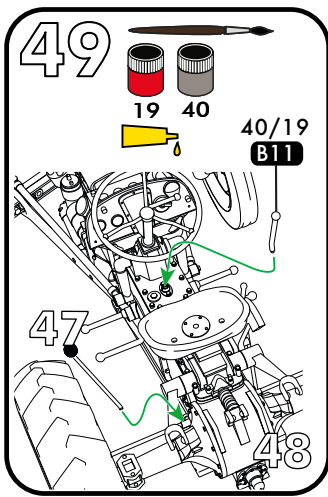

60

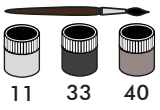

FERGUSON TE-20

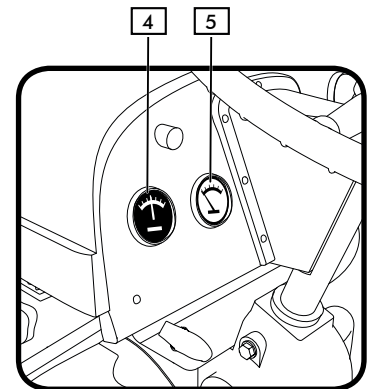
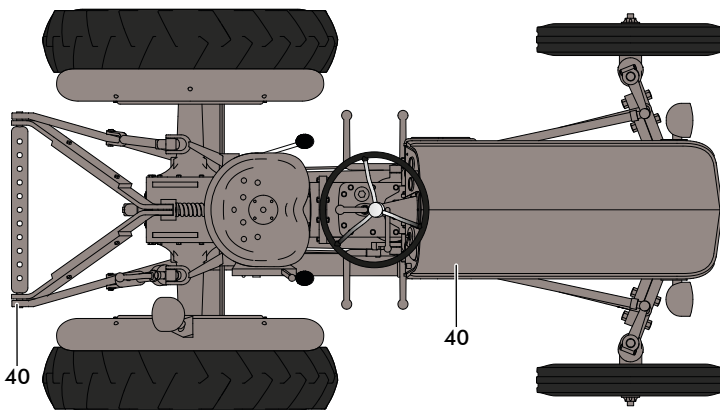
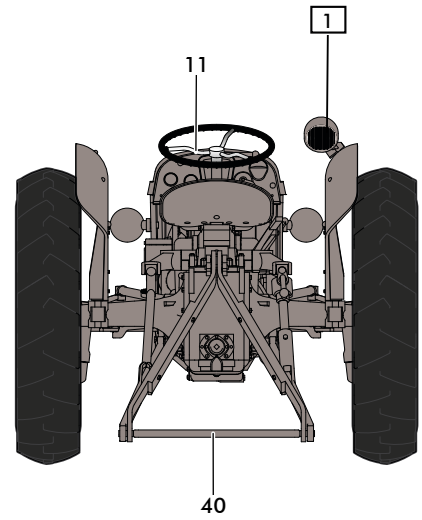
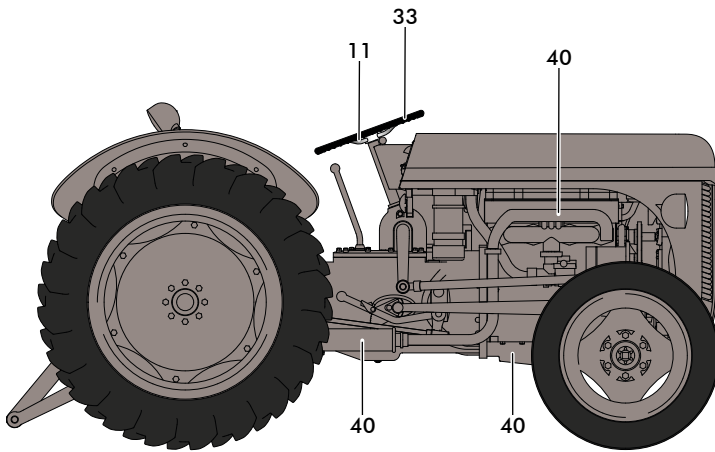
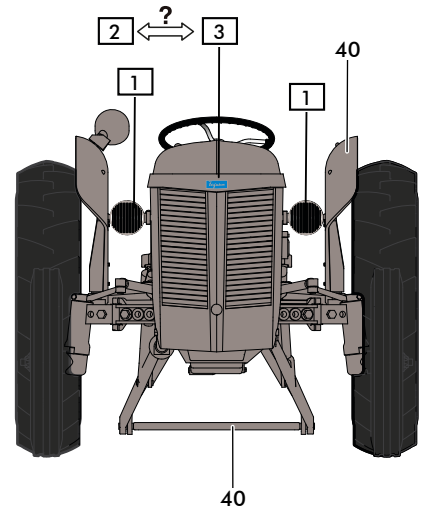
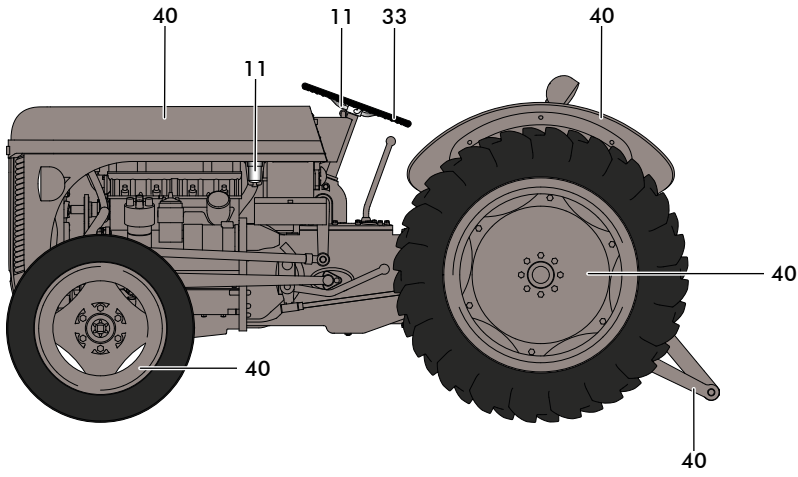

61



FERGUSON FF-30

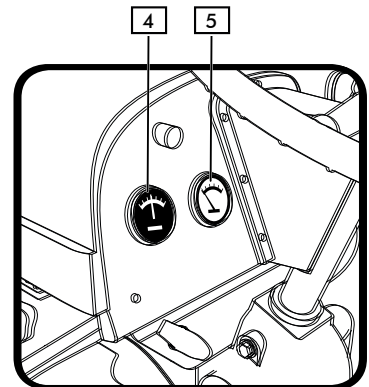
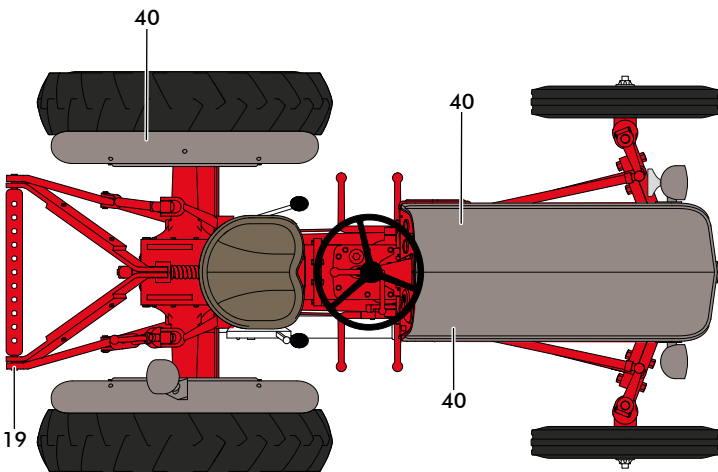
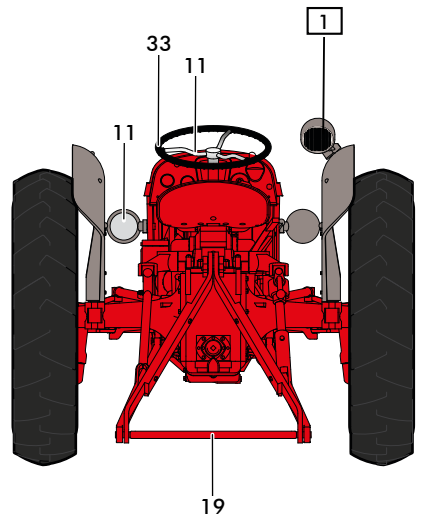
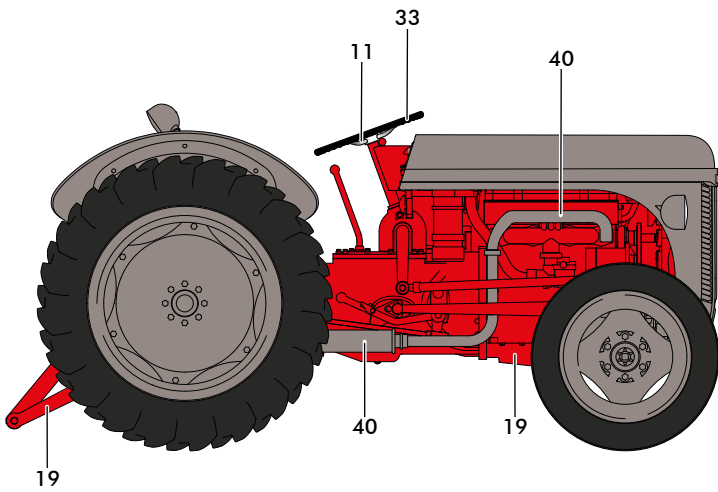
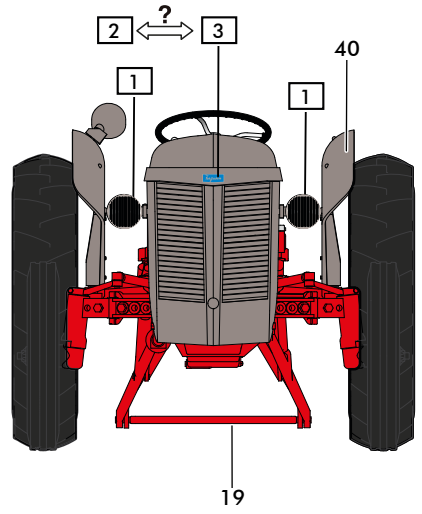
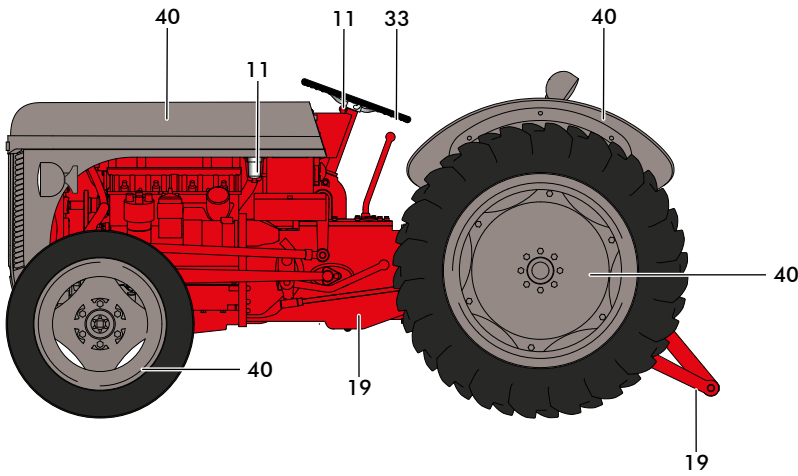

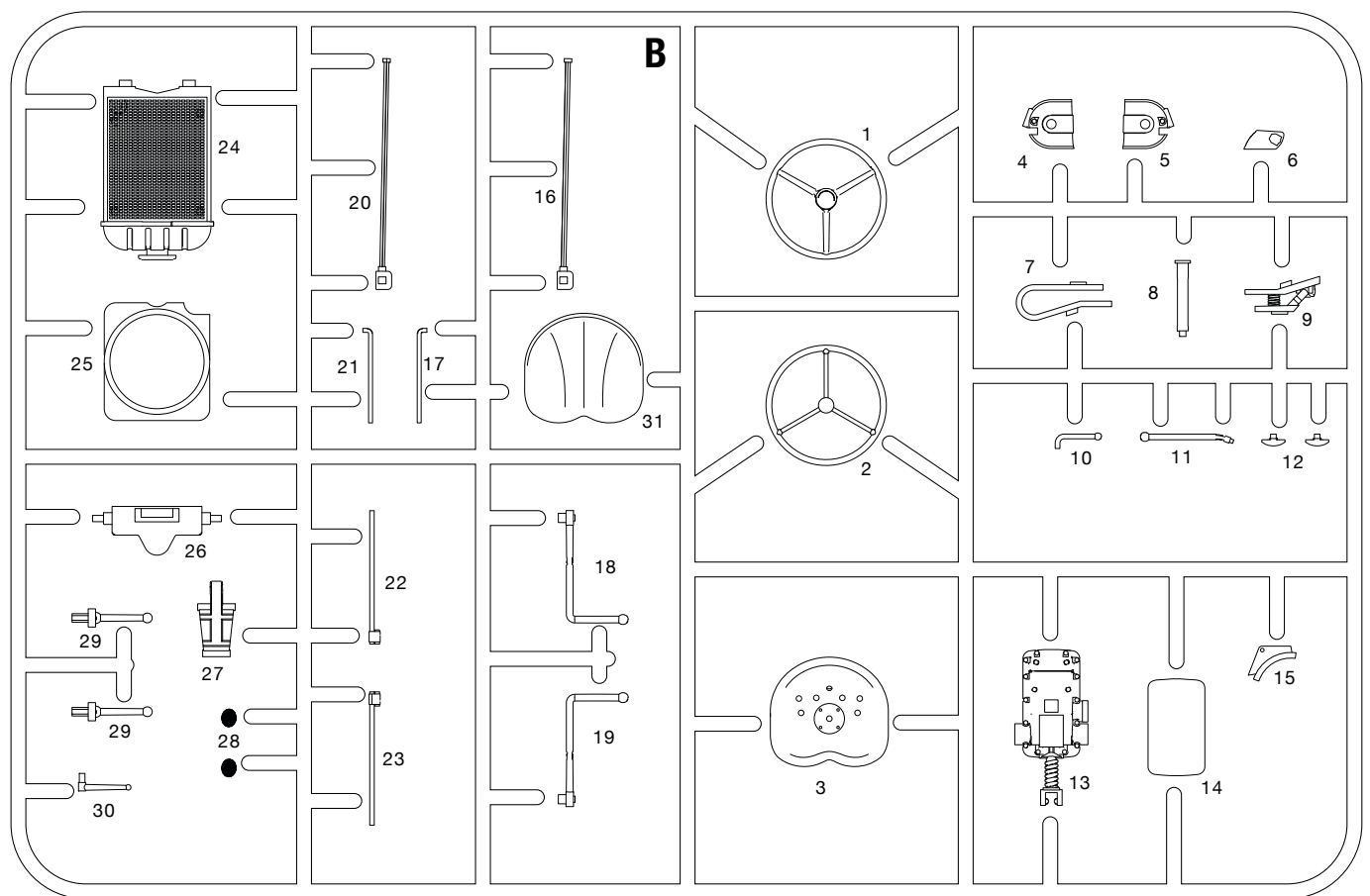
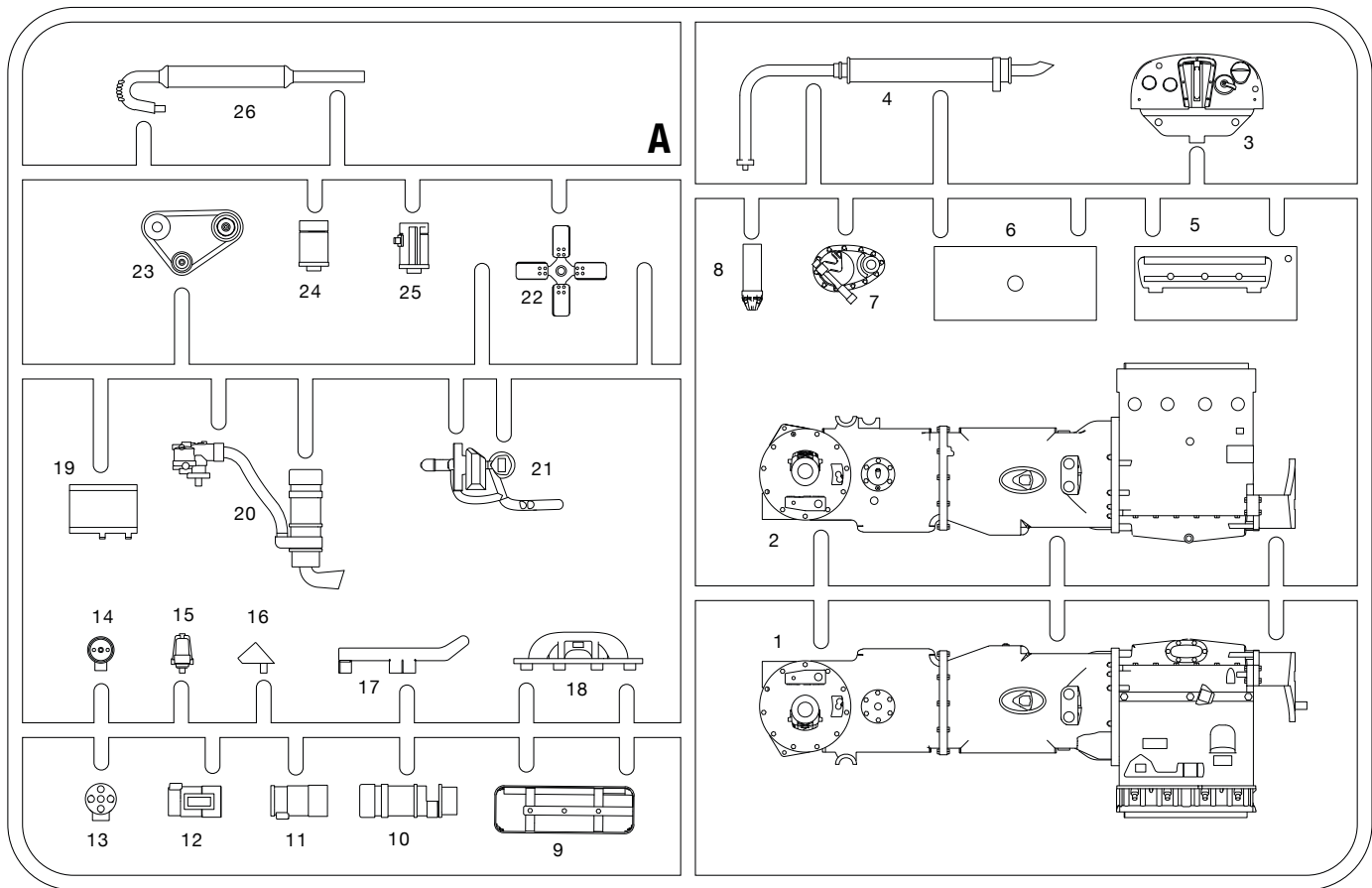

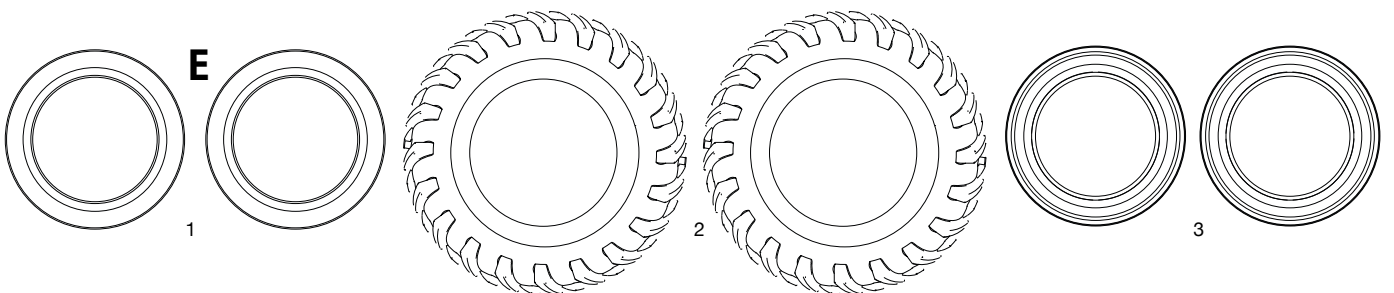
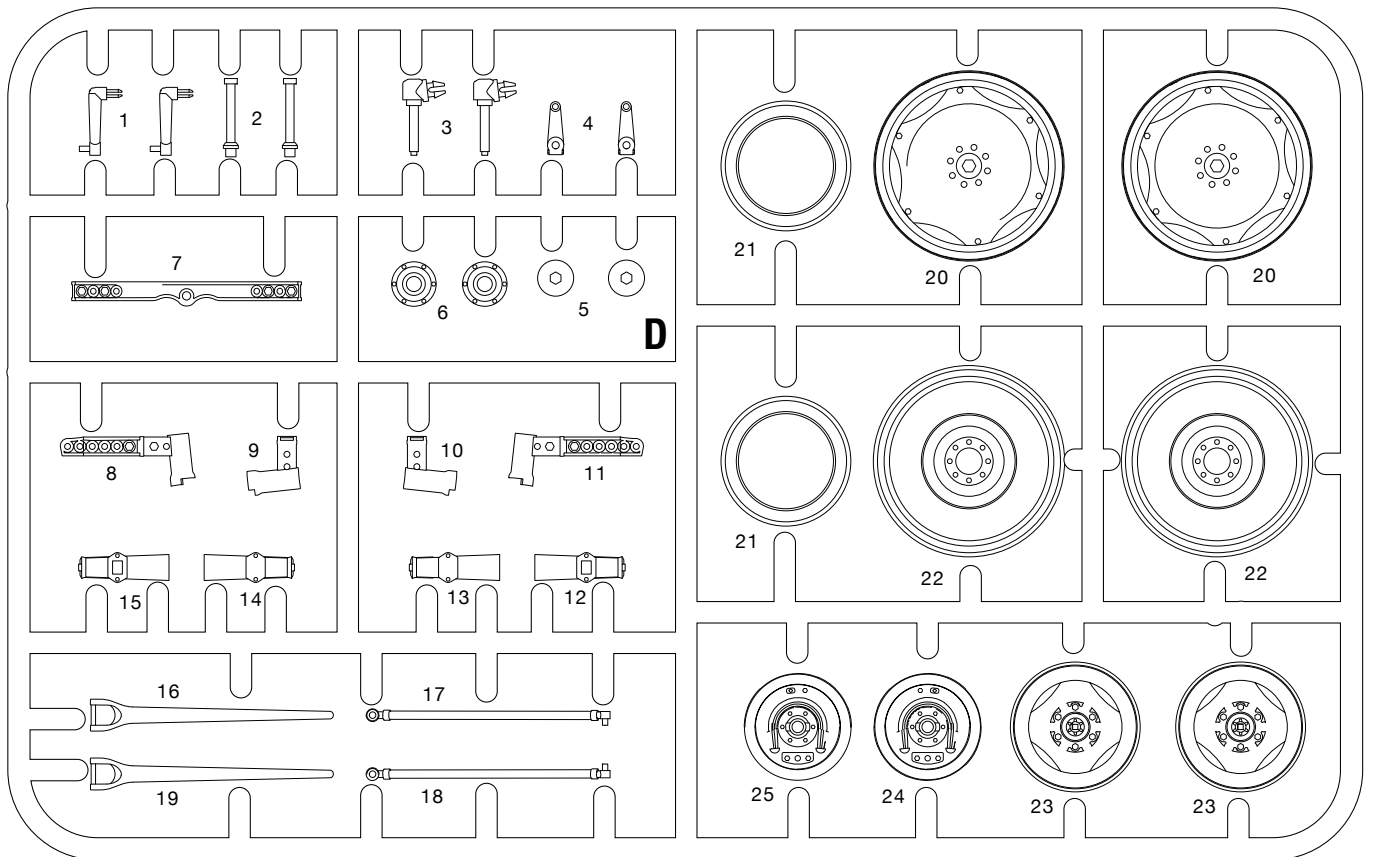
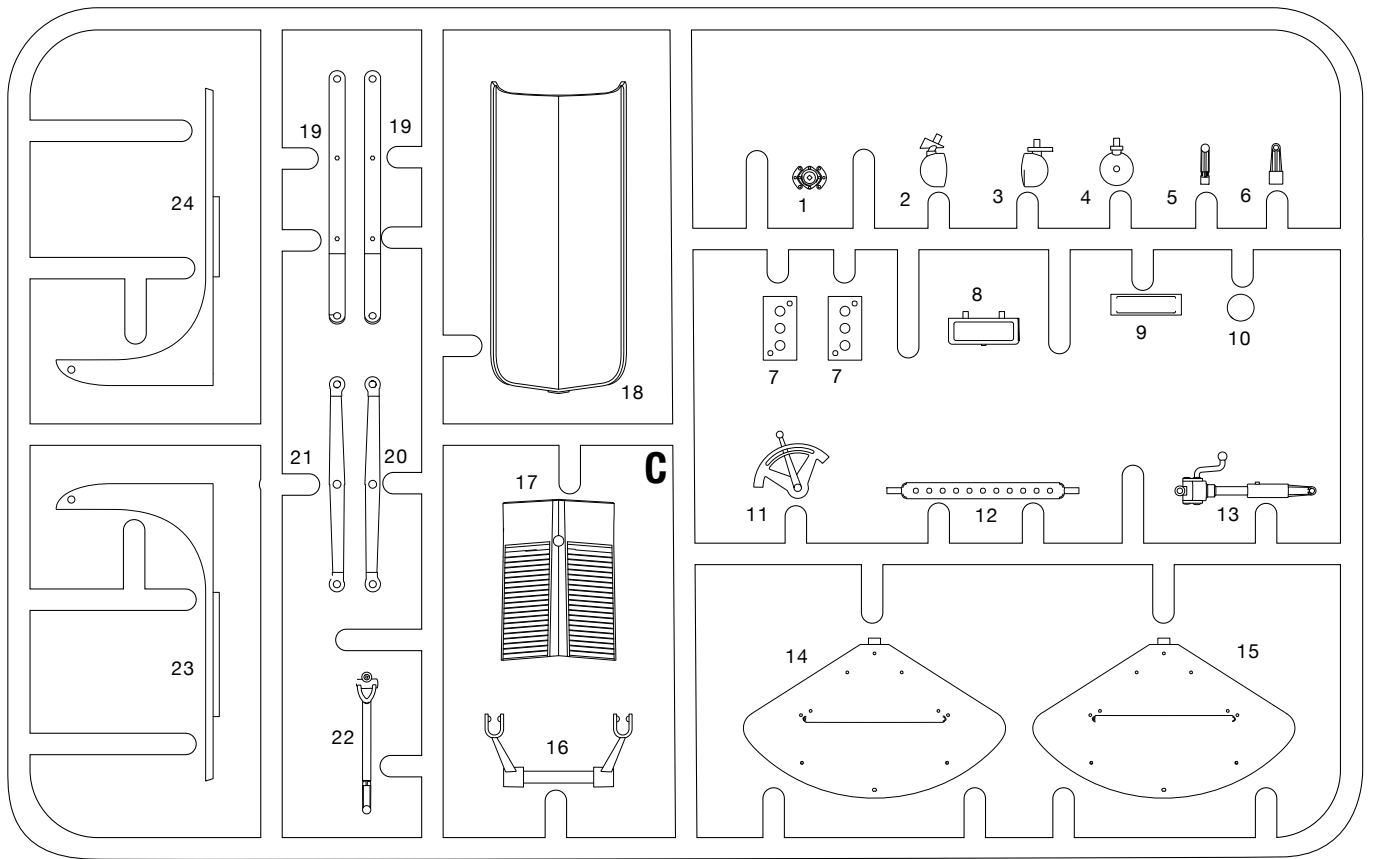

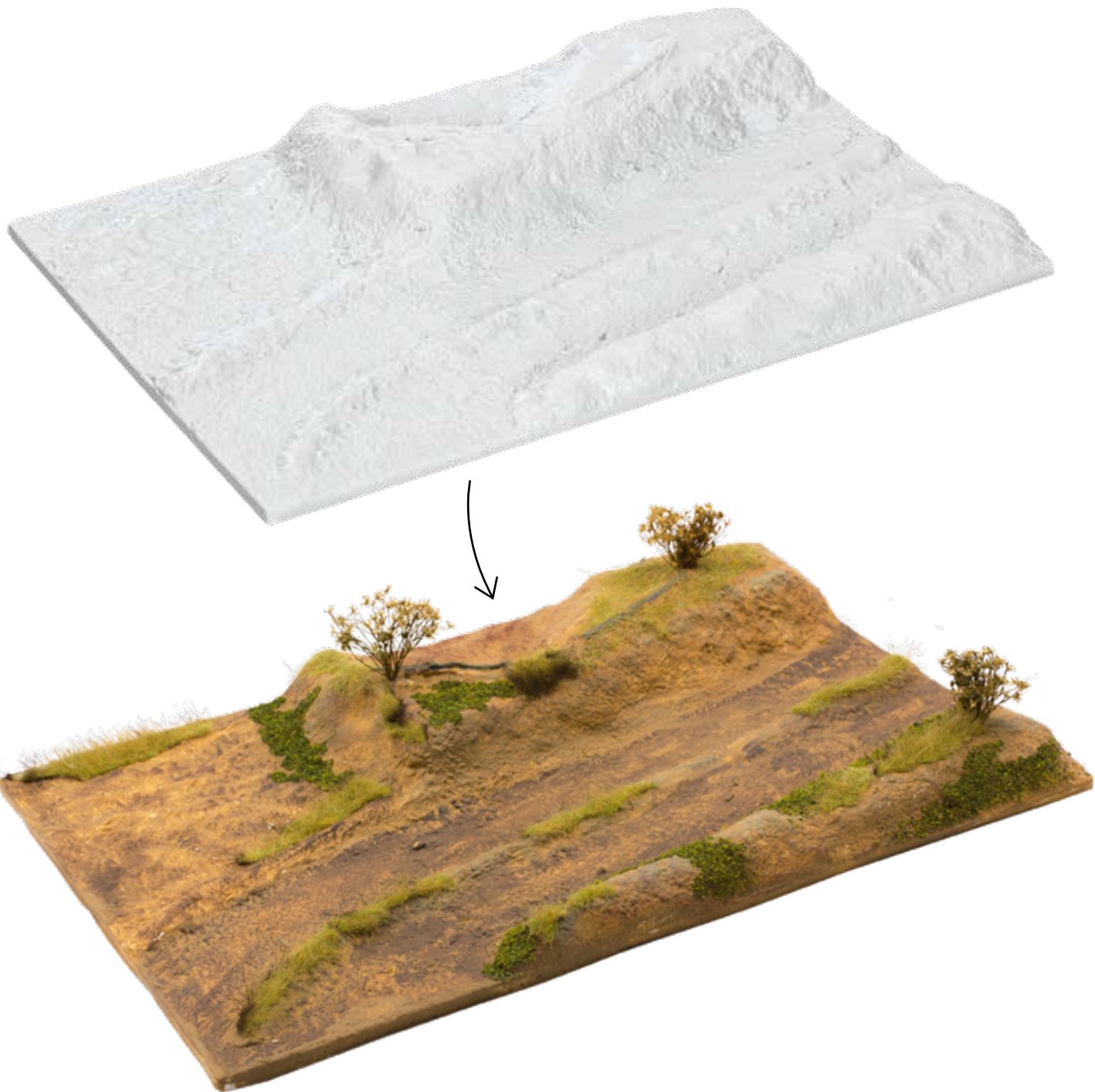

Français

Socle Diorama Campagne - Une fois peint et patiné, éventuellement enrichi d'éléments de décors disponibles chez votre détaillant, cet accessoire vous permettra d'obtenir avec un minimum de travail une scène de présentation idéale pour vos maquettes.

English

DIORAMA CAMPAGNE base - Once painted and patinated, possibly enriched with decor elements available at your retailer, this accessory will allow you to obtain with a minimum of work an ideal presentation scene for your models.

Deutsch

Diorama Landschaft - Bemalt und patiniert, möglicherweise mit Dekorelementen erweitert, die bei Ihrem Fachhändler erhältlich sind, können Sie mit diesem Zubehör und einem Minimum an Arbeit, eine ideale Präsentationsszenerie für Ihre Modelle gestalten.

Español

Diorama de paisaje - Una vez pintado y patinado, y enriquecido opcionalmente con elementos decorativos disponibles en su distribuidor, con estos accesorios y un mínimo de trabajo puede crear un escenario de presentación ideal para sus modelos.

Italiano

Plastico paesaggio - Dipinto e patinato, eventualmente arricchito con elementi decorativi disponibili presso il tuo rivenditore, questo accessorio, con un minimo di lavoro, ti permette di creare un'ambientazione ideale per i tuoi modelli.

Nederlands

Diorama natuurlandschap - Wanneer dit accessoire eenmaal geverfd en gepatineerd is en eventueel verrijkt met decoratieve elementen die verkrijgbaar zijn bij uw winkelier, kunt u met een minimum aan werk zorgen voor een ideale presentatiescène voor uw modellen.

DÉCOUVREZ LE MONDE DES PEINTURES ACRYLIQUES HELLER !

DISCOVER THE WORLD OF HELLER ACRYLIC PAINTS!

ENTDECKEN SIE DIE WELT DER HELLER ACRYL-FARBEN!

NEW



- FACILE À UTILISER
- DILUABLE À L'EAU
- POTS DE PEINTURE STABLES
- BOUCHON À VIS SÉCURISÉ

- EASY TO USE
- DILUTABLE WITH WATER
- STABLE PAINT CANS
- SECURE SCREW CAP

- EINFACHE ANWENDUNG
- MIT WASSER VERDÜNNBAR
- STANDFESTE FARBDOSEN
- SICHERER SCHRAUBVERSCHLUSS

VISITEZ-NOUS EN LIGNE !

VISIT US DIGITALLY!
BESUCHEN SIE UNS DIGITAL!

 www.heller.fr
 [instagram.com/heller.fr](https://www.instagram.com/heller.fr)
 [facebook.com/heller.fr](https://www.facebook.com/heller.fr)



Choisissez l'article désiré et téléchargez la notice de montage.

Choose your desired article and download the instructions.

Wählen Sie den gewünschten Artikel und laden Sie die Anleitung herunter.

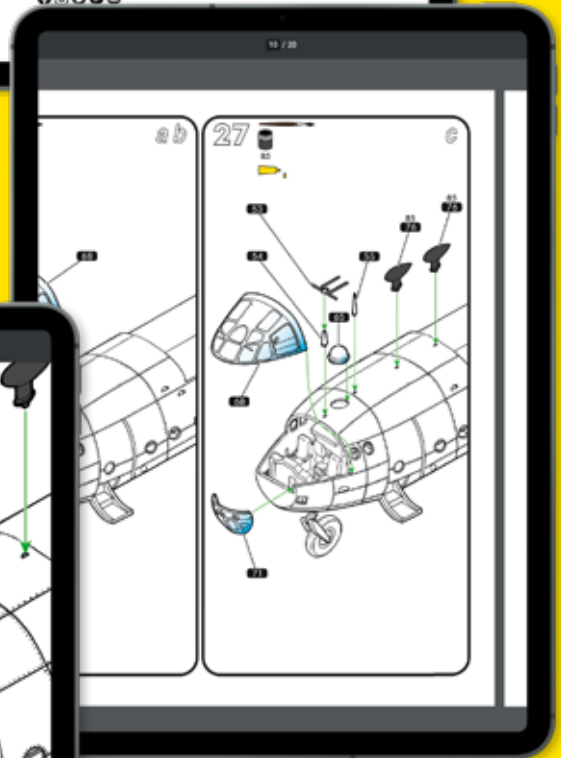

**Download all
instructions!**

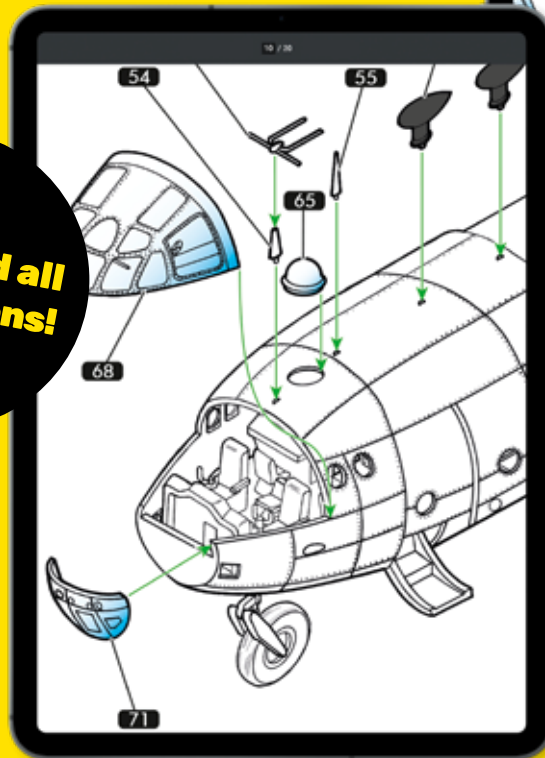

**Grossissement des instructions pour
une vue détaillée.**

Enlarge the instructions for a more
detailed view.



Vergrößern Sie die Anleitung für eine
detailliertere Ansicht.

V-060922

Service consommateurs
Pour toute demande de SAV, connectez-vous
sur notre site www.heller.fr.

Customer Service
For after-sales service requests,
please contact us through our website
www.heller.fr.

Endverbraucherservice
Bitte besuchen Sie uns auf www.heller.fr
für alle Ersatzteilanfragen.

Heller Hobby GmbH
Erlenbacher Str. 3 • 42477 Radevormwald • GERMANY
 +49 (0) 2195-92773-0  info@heller.fr